

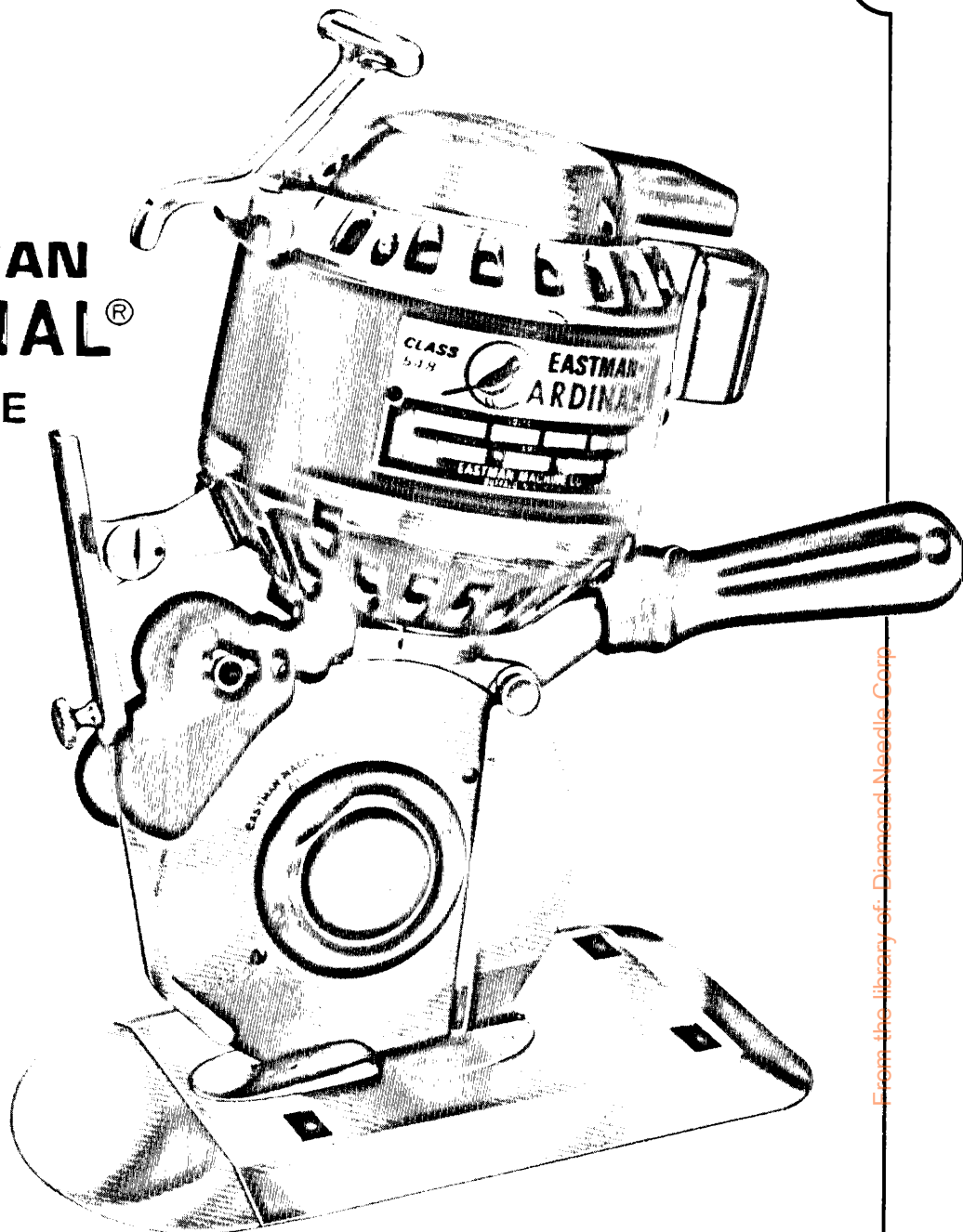

**EASTMAN
CARDINAL®**

**ROUND KNIFE
MACHINES**

**CLASS 534, 548
AND 562**



CAUTION

**MACHINE EQUIPPED
WITH
SHARP BLADE**

From the library of: Diamond Needle Corp

INSTRUCTION BOOK AND PARTS LIST

**Eastmanmachine
COMPANY**

779 Washington St. • Buffalo, N.Y., U.S.A. 14203

• 716/856-2200 • Telex 4432018 • Cable EMC0BUF • Fax 716/856-1140

EASTMAN DEPENDABILITY, EASTMAN QUALITY AND EASTMAN SERVICE ARE YOUR GUARANTEE THAT EASTMAN CUTTERS CUT CUTTING COSTS. THERE'S AN EASTMAN FOR EVERY CUTTING NEED.



**EASTMAN
CARDINAL®**

MAINTENANCE INSTRUCTIONS

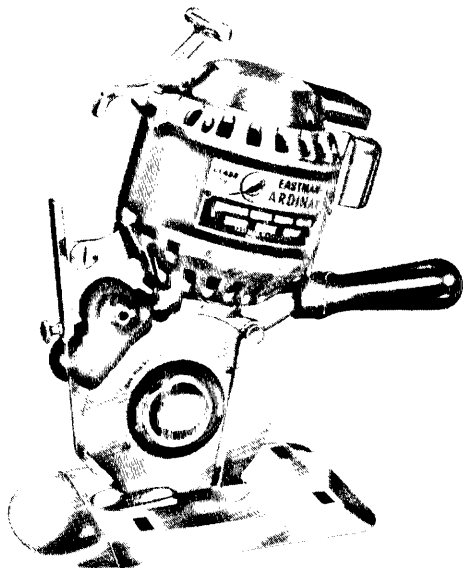

The purchaser must instruct all operators on the proper use of the equipment. All standard industrial safety measures and equipment should be provided to protect the operator. Operators must be cautioned that improper use of this equipment can cause bodily injury. If you do not have qualified operators to instruct new persons, contact your Eastman sales representative or write to Eastman Machine factory direct.

CAUTION

Read instructions carefully before starting motor. Be sure that voltage and current are the same as stamped on nameplate. All Eastman machines shown in this catalogue are equipped with sharp blades and extreme caution should be used when this machine is put into use. Use control levers and handles only when operating or handling machine. When machine is not in operation the front knife guard should be kept in the lowered position. When making a cut the knife guard should be raised only enough to clear the material being cut. When this equipment is not being utilized, the power supply should be disconnected from the equipment.

TO OPERATE MACHINE

Turn the switch to the on position; if cutter does not start immediately, return the switch to the off position. Check the line output and be sure that the unit is plugged in properly and is making full contact, then repeat procedure. Do not attempt to start this unit while it is in the material being cut.

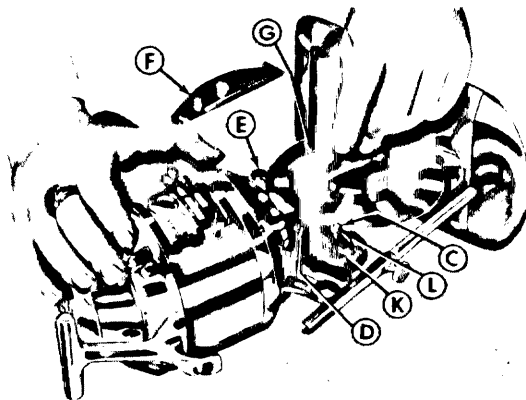

SPANNER WRENCH



SMALL PIN

WARNING

Before performing any of the following procedures, make sure that the attachment plug has been disconnected from power source.

MAINTENANCE PROCEDURES

- 1 Be sure that the rollers of the base plate are kept lint free.
- 2 Be sure that the terminal pins on the terminal block are kept in good condition to make full contact with the female receptacle.
- 3 Inspect the operating switch periodically to make sure that it is making full contact when in the on position.
- 4 When replacing the knife on this cutting unit, be sure that any lint build-up between the knife and the standard is cleaned out.
- 5 If the cutting unit seems to lag while not cutting, the knife should be removed and the unit should be run without the knife to see if the machine has been over-greased or if there is an obstruction somewhere.

TO REPLACE THE KNIFE

Loosen thumb screw "E" and swing guard "F" to outward position as shown on dotted lines. Turn the knife so the small hole lines up with hole "G" in the standard. Insert the small pin that is with the supplies in hole "G". Remove the lock nut that retains the blade with the special spanner wrench. When installing a new knife, be sure the name Eastman Machine Company is facing outward and that the knife seats on the knife gear. Install knife lock nut and be sure that the throat plate is adjusted as outlined.

CAUTION

Discard used sharp knives with care.

TO ADJUST THROAT PLATE

It is very important that the edge of the knife be as close as possible without touching to the forward position in the slot on the throat plate. The slot in the throat plate "J" should straddle the blade and screws "H" can be loosened and retightened to accomplish this adjustment.

CAUTION

Do not use sewing machine oil or detergent oil. It is entirely too light for cutting machine lubrication. For best results use specially compounded Eastman Oil or at least a good grade of No. 30 motor oil. Do not oil Base Plate Rollers.

REPLACEMENT KNIVES

Knife Diameter	Carbon Steel	High Speed Steel	High Speed Steel Grooved	High Speed Steel Teflon Coated	Model Used On
3-1/2	80C1-26	-	-	-	-
4	80C1-59	80C1-59 HS	80C1-59 HSG	80C1-59 HST	534, 548
5	80C1-101	80C1-101 HS	80C1-101 HSG	80C1-101 HST	534, 548
5-1/4	80C1-61	80C1-61 HS	80C1-61 HSG	80C1-61 HST	548
6	80C1-39	80C1-39 HS	80C1-39 HSG	80C1-39 HST	548, 562
7-1/2	80C1-77/100	80C1-77/100 HS	80C1-77/100 HSG	80C1-77/100 HST	562

Knife Diameter	Carbon Slotted	Double-Bevel Hi-Speed
7-1/2	80C1-120	80C1-154

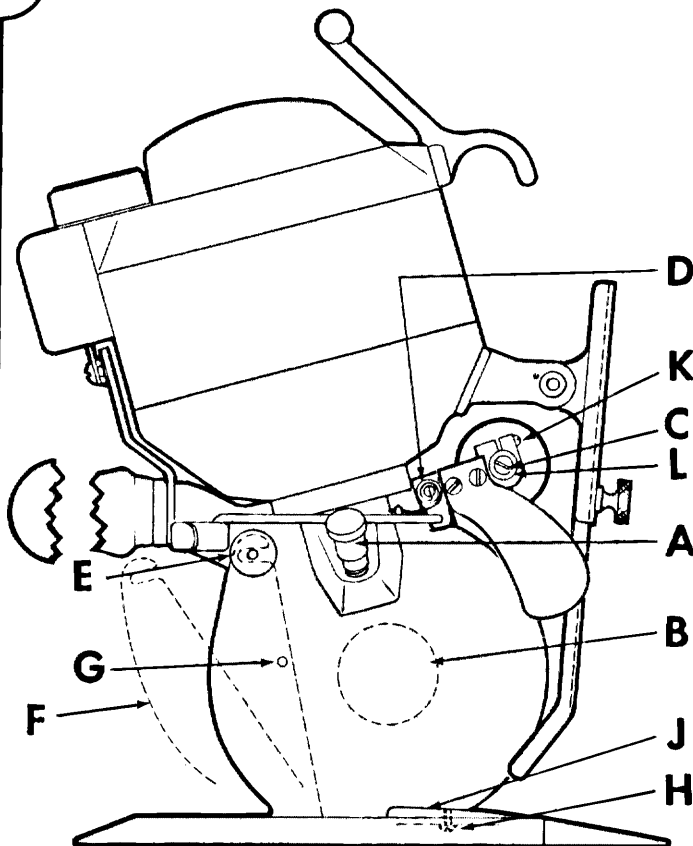

LUBRICATION

TWICE A DAY

Oil emery wheel spindles at "C".
DO NOT USE AN EXCESS AMOUNT OF OIL.

ONCE A DAY

Lubricate gears, screw grease cup "A" down one-half turn. Refill cup, as required with Eastman Gear Lubricant special formula (242C2).

ONCE A MONTH

Grease knife gear bearing at "B", remove bearing locknut with spanner wrench and a small amount of Eastman Lubriko grease (242C2-2) from tube.

We recommend our Eastman Gear Lubricant special formula (242C2) for gears and Eastman Lubriko grease (242C2-2) for knife gear ball bearing. Do not use Eastman Gear Lubricant for ball bearings or Eastman Lubriko grease for gears.

TO ADJUST EMERY WHEELS

As the Emery Wheels wear away and become farther apart, they must be adjusted. Adjust Emery Wheels from both sides to assure proper centering of the wheels over the knife. Proceed as follows:

- 1 Loosen slotted head screws "K".
- 2 With fingers, turn adjusting bushings "L" until Emery Wheels are as close together as possible without touching and are centered over the knife. Both wheels should grind at the same time when pressed lightly against the knife and there should be no more than 1/32-inch clearance between the two Emery Wheels.
- 3 Tighten slotted head screws "K".

TO REPLACE EMERY WHEELS

- 1 With front of machine facing serviceman, guard rod in down safe position, remove right hand grinding wheel and arm by loosening setscrew "D" and sliding arm off shaft.

- 2 Remove slotted head screw "C" and replace grinding wheel with spindle in right hand arm.
- 3 No need to remove left hand arm from machine. Remove slotted head screw "C" from left hand arm and replace grinding wheel with spindle.
- 4 Re-assemble right hand arm to shaft and adjust wheels to knife as covered above.

Eastmanmachine
COMPANY
778 WASHINGTON STREET
BUFFALO, NEW YORK 14203

ILLUSTRATED PARTS LIST



ROUND KNIFE MACHINES

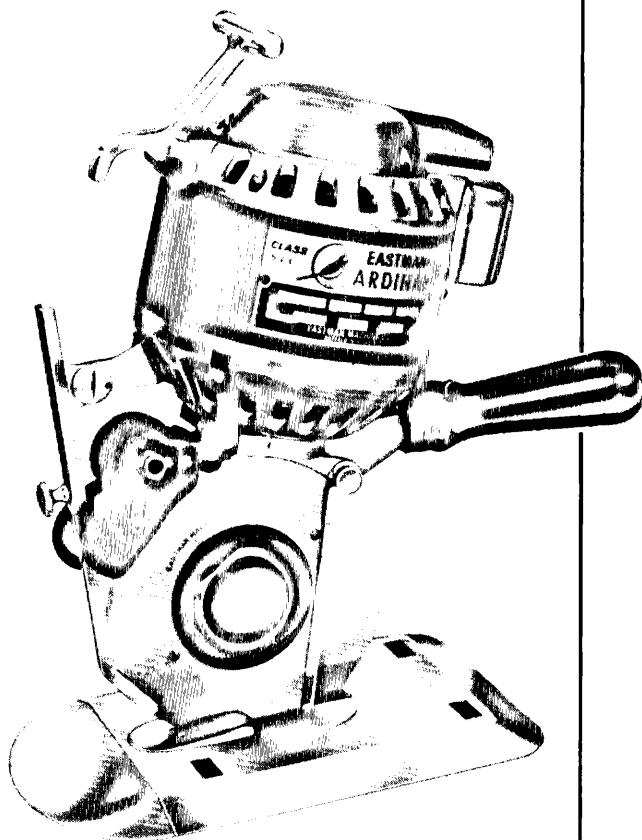

ALL PARTS SHOWN ON EXPLODED PARTS ILLUSTRATIONS ARE COMMON TO 548 AND 534 MODELS EXCEPT AS NOTED BY SYMBOLS.

*PARTS REQUIRED FOR MODEL 534 ONLY
†PARTS REQUIRED FOR MODEL 548 ONLY

Your Eastman Cardinal Round Knife has been carefully designed to provide many hours of trouble free operation. These comprehensive exploded parts illustrations have been carefully prepared to enable you to easily order replacement parts, as required. Replacement parts for this machine may be ordered thru your nearest Eastman representative or directly from the Eastman factory.

IMPORTANT

Always specify machine class number and serial number when ordering parts for faster more efficient service.

EXPLODED PARTS ILLUSTRATIONS

The exploded parts illustrations and parts lists in this section have been divided into major assemblies as follows:

INDEX

CLASS 534 AND 548

KNIVES, REPLACEMENT	PAGE 3
MOTOR ASSEMBLY, SINGLE PHASE	PAGES 6, 7
MOTOR ASSEMBLY, THREE PHASE	PAGES 8, 9
SHARPENER ASSEMBLY	PAGES 10, 11
STANDARD ASSEMBLY	PAGES 12, 13
GUARD ASSEMBLY	PAGES 14, 15
BASE PLATE ASSEMBLY	PAGES 14, 15
BK & CARPET CUTTER	PAGES 16, 17
TERMINAL BLOCK, ATTACHMENT PLUG	PAGE 18
CLASS 562	PAGE 19

FASTENERS REQUIRED TO ASSEMBLE MAJOR COMPONENTS

Part No.	Description
20C8-2	SHARPENER LEVER SCREW
20C13-72	SCREW, BASE PLATE TO STANDARD (3 Req'd.)
300C12-3	SCREW, 8-32 x 3/8 RD. HD. (2 Req'd.)
301C14-5	SCREW, 10-24 x 3/4 FILLISTER HD. (3 Req'd.)
302C12-3	SCREW, 8-32 x 3/8 FLAT HD. (2 Req'd.)

MOTOR ASSEMBLIES
SEE PAGES 6, 7, 8 AND 9

GUARD ASSEMBLY
SEE PAGES 14 AND 15

300C12-3

STANDARD ASSEMBLY
SEE PAGES 12 AND 13

302C12-3

SHARPENER ASSEMBLY
SEE PAGES 10 AND 11

20C8-2

301C14-5

BASE PLATE ASSEMBLY
SEE PAGES 14 AND 15

20C13-72

ALL PARTS SHOWN ON EXPLODED PARTS ILLUSTRATIONS ARE COMMON TO 548 AND 534 MODELS EXCEPT AS NOTED BY SYMBOLS.

*PARTS REQUIRED FOR MODEL 534 ONLY
†PARTS REQUIRED FOR MODEL 548 ONLY

Eastmanmachine

COMPANY

778 WASHINGTON STREET
BUFFALO, NEW YORK 14203

From the library of: Diamond Needle Corp



**ROUND KNIFE
MACHINES**

**SINGLE PHASE
MOTOR
ASSEMBLY**

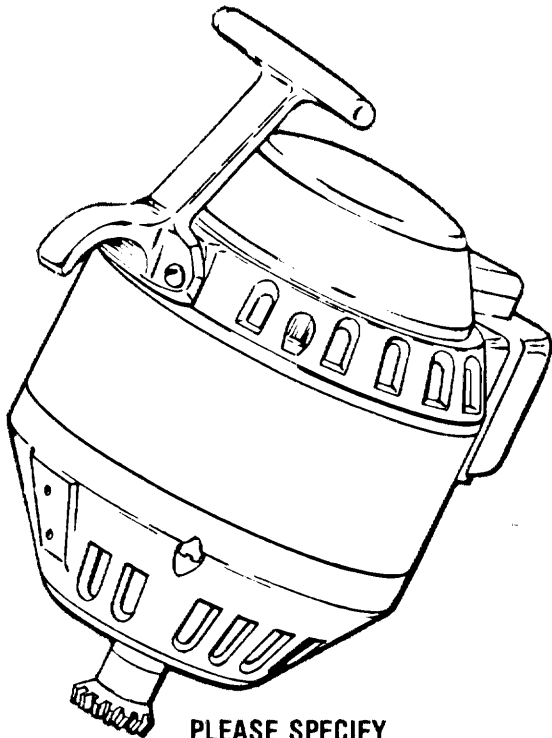

**PLEASE SPECIFY
MACHINE CLASS NUMBERS
AND SERIAL NUMBER WHEN
ORDERING PARTS**

ALL PARTS SHOWN ON EXPLODED PARTS
ILLUSTRATIONS ARE COMMON TO 548 AND
534 MODELS EXCEPT AS NOTED BY SYMBOLS.

*PARTS REQUIRED FOR MODEL 534 ONLY
†PARTS REQUIRED FOR MODEL 548 ONLY
★INCLUDES KNIFE DRIVE GEAR (See Pg. 13)

Part No.	Description
+ 1C5-30	DRIVE GEAR SPACING SLEEVE 52H
+ 1C5-31	DRIVE GEAR SPACING SLEEVE 6H
1C5-32	DRIVE GEAR SPACING SLEEVE 4H
+ 1C5-33	DRIVE GEAR SPACING SLEEVE 5H
+ 1C5-34	DRIVE GEAR SPACING SLEEVE 6L
+ 1C5-36	DRIVE GEAR SPACING SLEEVE 52L
4C1-87	FRONT BALL BEARING LOCKNUT
4C1-118	SHAFT LOCKNUT
* 4C1-180	NUT BEARING SCREW (4 Req'd)
+ 4C1-186	NUT BEARING SCREW (4 Req'd)
+ 4C2-91	LEVER NUT
+ 8C4-14	SWITCH INSULATION
* 8C4-20	SWITCH INSULATION
8C4-72	SWITCH INSULATION
8C5-10	AUTOMATIC SWITCH INSULATION
+ 10C2-27	ROTOR FAN
* 10C2-30	ROTOR FAN
12C1-12	SPRING WASHER
12C1-32	LOCK WASHER
12C11-17	DRIVE GEAR SPACING WASHER 4H/5H
+ 12C11-18	DRIVE GEAR SPACING WASHER 52H/52L/6H/6L
199C1-19	TONGUE RINGS 4-1PH/7-3PH
* 20C3-37	FRONT TO REAR BEARING SCREW (4 Req'd)
+ 20C3-31	FRONT TO REAR BEARING SCREW (4 Req'd)
+ 20C12-64	LEVER SCREW
+ 22C1-32	CARRYING HANDLE
* 22C1-33	CARRYING HANDLE
* 25C5-48	GUARD OVER TERMINAL PINS
+ 25C5-57	GUARD OVER TERMINAL PINS
+ 52C5-171	SWITCH BASE
* 52C5-175	SWITCH BASE
+ 53C2-104	SWITCH COVER
* 53C2-107	SWITCH COVER
+ 53C7-36	REAR BEARING COVER
* 53C7-39	REAR BEARING COVER
+ 90C1-153	REAR BEARING HOUSING
* 90C1-158	REAR BEARING HOUSING
+ 90C2-143	FRONT BEARING HOUSING
* 90C2-146	FRONT BEARING HOUSING
90C6-46	REAR BALL BEARING
90C6-29	FRONT BALL BEARING
199C1-19	WIRE LUG (4Req'd.)
300C7-2	SCREW, 4-36 X 3/16 ROUND HD. (2 Req'd.)
300C10-2	SCREW, 6-32 X 1/4 ROUND HD. (2 Req'd.)
300C10-4	SCREW, 6-32 X 3/8 ROUND HD. (2 Req'd.)
300C12-3	SCREW, 8-32 X 3/8 ROUND HD. (2 Req'd.)
300C14-4	SCREW, 10-24 X 1/2 ROUND HD. (2 Req'd.)
301C10-3	SCREW, 6-32 X 3/8 FILL. HD. (2 Req'd. 534) (3 Req'd 548)
305C10-1	SCREW, 6-32 X 1/4 BIND HD.
+ 513C3-230	ROTOR WITH SHAFT 52H
+ 513C3-231	ROTOR WITH SHAFT 52L
+ 513C3-232	ROTOR WITH SHAFT 4H
+ 513C3-233	ROTOR WITH SHAFT 5H
+ 513C3-234	ROTOR WITH SHAFT 6H
+ 513C3-235	ROTOR WITH SHAFT 6L
* 513C3-221	ROTOR WITH SHAFT 4H
+ 514C4-206	STATOR WITH BAND 110V, 60cy, 3600 R.P.M.
+ 514C4-207	STATOR WITH BAND 220V, 60cy, 3600 R.P.M.
+ 514C4-208	STATOR WITH BAND 220V, 50cy, 3000 R.P.M.
+ 514C4-209	STATOR WITH BAND 110V, 50cy, 3000 R.P.M.
+ 514C4-241	STATOR WITH BAND 110V, 50/60cy, 3600 R.P.M.
* 514C4-242	STATOR WITH BAND 220V, 60cy, 3600 R.P.M.
* 514C4-243	STATOR WITH BAND 220V, 50cy, 3000 R.P.M.
+ 514C4-210	STATOR WITH BAND 110V, 50cy, 1500 R.P.M.
+ 514C4-211	STATOR WITH BAND 110V, 60cy, 1800 R.P.M.
+ 514C4-212	STATOR WITH BAND 220V, 50cy, 1500 R.P.M.
580C1-70	AUTOMATIC CUTOUT SWITCH
+ *580C1-85	MOTOR SWITCH
597C2-21	AUTOMATIC CUTOUT (w/Sleeve) 60cy, 3600 R.P.M.
597C2-22	AUTOMATIC CUTOUT (w/Sleeve) 50cy, 3000 R.P.M.
597C2-23	AUTOMATIC CUTOUT (w/Sleeve) 60cy, 1800 R.P.M.
597C2-24	AUTOMATIC CUTOUT (w/Sleeve) 50cy, 1500 R.P.M.
†★ 675C1-11	DRIVE GEAR SET 4H/5H
†★ 675C1-14	DRIVE GEAR SET 52H/6H
★ 675C1-15	DRIVE GEAR SET 52L/6L
783C1-3	GROUND WIRE

From the library of: Diamond Needle Corp

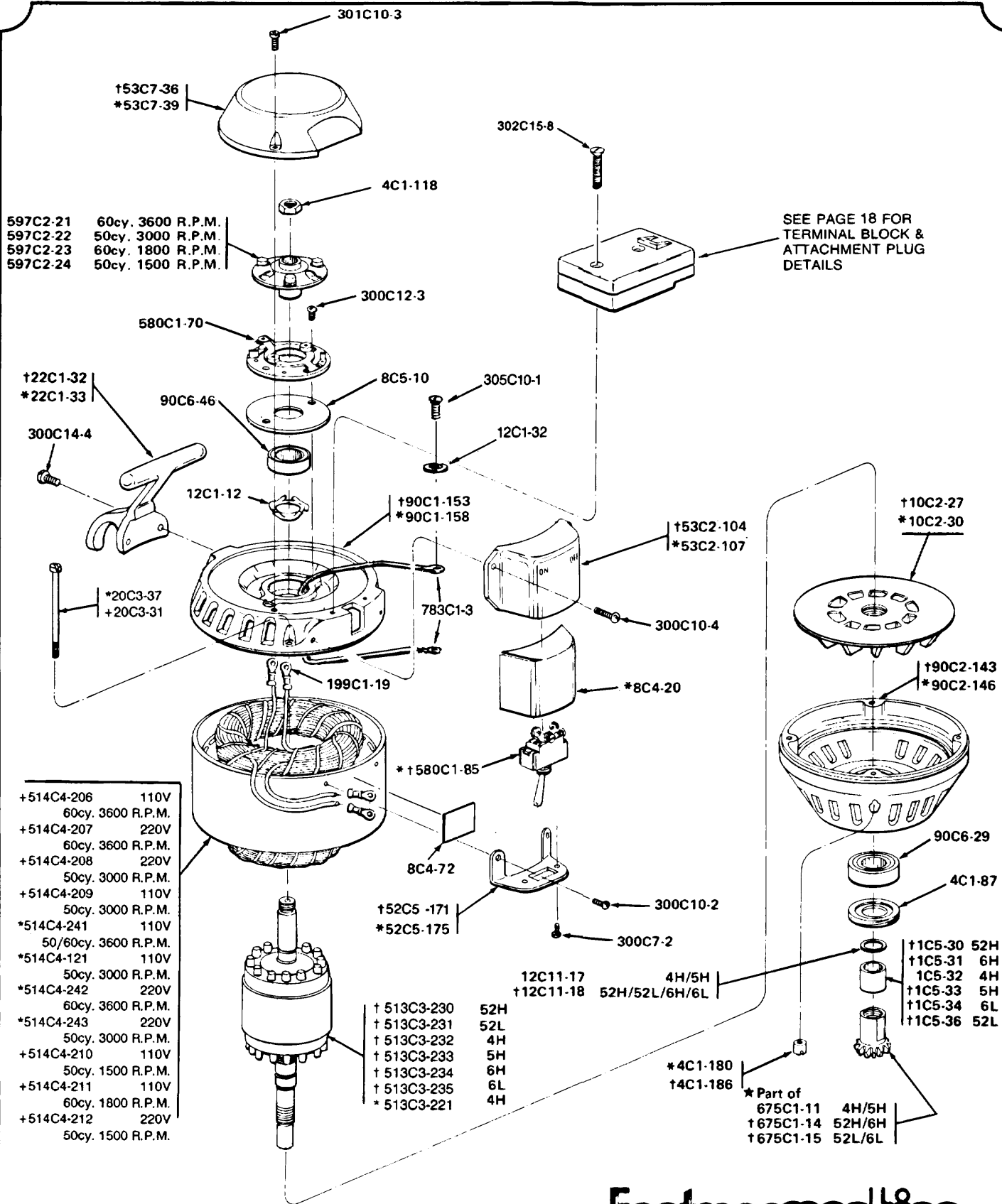

From the library of: Diamond Needle Corp

ALL PARTS SHOWN ON EXPLODED PARTS ILLUSTRATIONS ARE COMMON TO 548 AND 534 MODELS EXCEPT AS NOTED BY SYMBOLS.

*PARTS REQUIRED FOR MODEL 534 ONLY
†PARTS REQUIRED FOR MODEL 548 ONLY
‡INCLUDES KNIFE DRIVE GEAR (See Pg. 13)

Eastmanmachine COMPANY

779 WASHINGTON STREET
BUFFALO, NEW YORK 14203



**EASTMAN
CARDINAL®**

**ROUND KNIFE
MACHINES**

**THREE PHASE
MOTOR
ASSEMBLY**

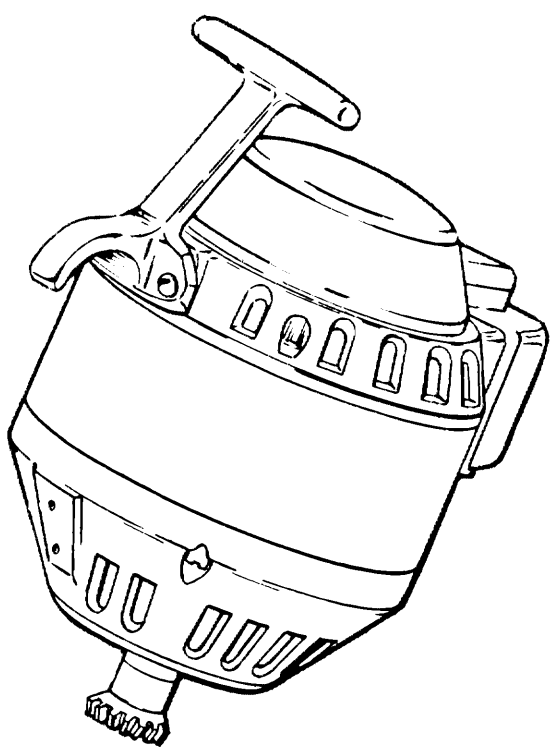

**PLEASE SPECIFY
MACHINE CLASS NUMBERS
AND SERIAL NUMBER WHEN
ORDERING PARTS**

ALL PARTS SHOWN ON EXPLODED PARTS
ILLUSTRATIONS ARE COMMON TO 548 AND
534 MODELS EXCEPT AS NOTED BY SYMBOLS.

*PARTS REQUIRED FOR MODEL 534 ONLY
†PARTS REQUIRED FOR MODEL 548 ONLY
★INCLUDES KNIFE DRIVE GEAR (See Pg. 13)

Part No.	Description
1C4-10	SPACING SLEEVE
+ 1C5-30	DRIVE GEAR SPACING SLEEVE 52H
+ 1C5-31	DRIVE GEAR SPACING SLEEVE 6H
1C5-32	DRIVE GEAR SPACING SLEEVE 4H
+ 1C5-33	DRIVE GEAR SPACING SLEEVE 5H
+ 1C5-34	DRIVE GEAR SPACING SLEEVE 6L
+ 1C5-36	DRIVE GEAR SPACING SLEEVE 52L
4C1-87	FRONT BALL BEARING LOCKNUT
4C1-118	SHAFT LOCKNUT
* 4C1-180	NUT BEARING SCREW (4 Req'd)
+ 4C1-186	NUT BEARING SCREW (4 Req'd)
4C2-116	HEX NUT
* 8C4-20	SWITCH INSULATION
+ 8C4-41	SWITCH INSULATION
8C4-72	SWITCH INSULATION
* 8C13-71	COVER INSULATION
+ 10C2-27	ROTOR FAN
* 10C2-30	ROTOR FAN
12C1-12	SPRING WASHER
12C1-32	LOCK WASHER
12C1-34	LOCK WASHER
12C11-17	DRIVE GEAR SPACING WASHER 4H/5H
+ 12C11-18	DRIVE GEAR SPACING WASHER 52H/52L/6H/6L
18C6-38	LOCATING RING
* 20C3-30	FRONT TO REAR BEARING SCREW (4 Req'd)
+ 20C3-31	FRONT TO REAR BEARING SCREW (4 Req'd)
+ 22C1-32	CARRYING HANDLE
* 22C1-33	CARRYING HANDLE
+ 52C5-171	SWITCH BASE
* 52C5-175	SWITCH BASE
+ 53C2-104	SWITCH COVER
* 53C2-107	SWITCH COVER
+ 53C7-36	REAR BEARING COVER
* 53C7-40	REAR BEARING COVER
+ 90C1-153	REAR BEARING HOUSING
* 90C1-158	REAR BEARING HOUSING
+ 90C2-143	FRONT BEARING HOUSING
* 90C2-146	FRONT BEARING HOUSING
90C6-46	REAR BALL BEARING
90C6-29	FRONT BALL BEARING
+ *199C1-19	WIRE LUG (4 Req'd.)
300C10-2	SCREW, 6-32 X 1/4 ROUND HD. (2 Req'd.)
300C10-4	SCREW, 6-32 X 3/8 ROUND HD. (2 Req'd.)
300C14-4	SCREW, 10-24 X 1/2 ROUND HD. (2 Req'd.)
301C10-3	SCREW, 6-32 X 3/8 FILL. HD. (2 Req'd. 534) (3 Req'd 548)
302C15-8	SCREW, 10-32 X 1-1/8 FLAT HD. (2 Req'd)
305C10-1	SCREW, 6-32 X 1/4 BIND HD.
+ 513C3-230	ROTOR WITH SHAFT 52H
+ 513C3-231	ROTOR WITH SHAFT 52L
+ 513C3-232	ROTOR WITH SHAFT 4H
+ 513C3-233	ROTOR WITH SHAFT 5H
+ 513C3-234	ROTOR WITH SHAFT 6H
+ 513C3-235	ROTOR WITH SHAFT 6L
* 513C3-221	ROTOR WITH SHAFT 4H
+ 514C4-213	STATOR WITH BAND 220V, 60cy, 3600 R.P.M.
* 514C4-244	STATOR WITH BAND 220V, 60cy, 3600 R.P.M.
* 514C4-245	STATOR WITH BAND 220V, 50cy, 3000 R.P.M.
+ 514C4-214	STATOR WITH BAND 220V, 50cy, 3000 R.P.M.
+ 514C4-215	STATOR WITH BAND 220V, 60cy, 1800 R.P.M.
580C1-65	MOTOR SWITCH
★ 675C1-11	DRIVE GEAR SET 4H/5H
†★ 675C1-14	DRIVE GEAR SET 52H/6H
†★ 675C1-15	DRIVE GEAR SET 52L/6L
783C1-3	GROUND WIRE

From the library of: Diamond Needle Corp

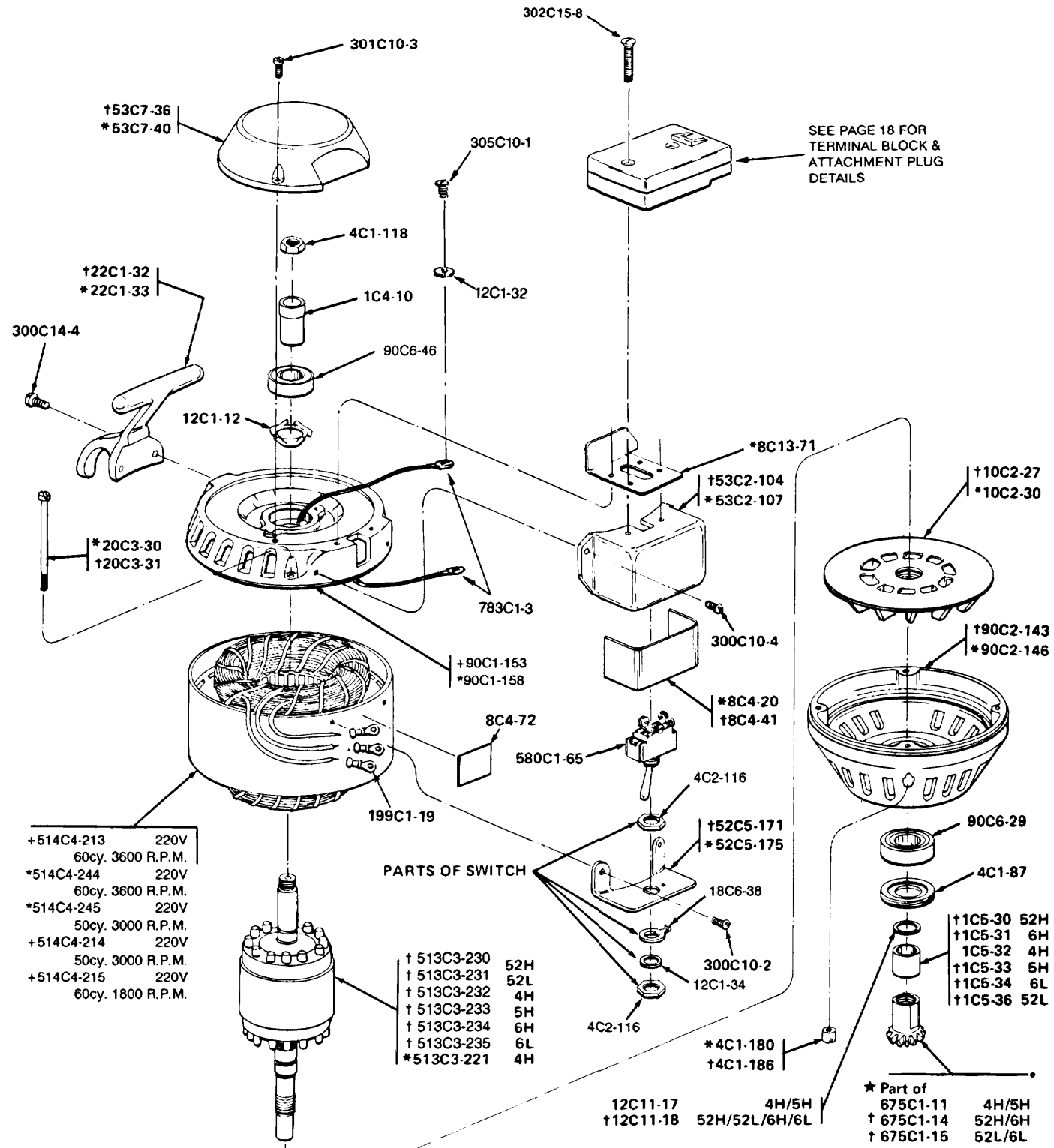

- +514C4-213 220V
60cy. 3600 R.P.M.
- *514C4-244 220V
60cy. 3600 R.P.M.
- *514C4-245 220V
50cy. 3000 R.P.M.
- +514C4-214 220V
50cy. 3000 R.P.M.
- +514C4-215 220V
60cy. 1800 R.P.M.

PARTS OF SWITCH

- † 513C3-230 52H
- † 513C3-231 52L
- † 513C3-232 4H
- † 513C3-233 5H
- † 513C3-234 6H
- † 513C3-235 6L
- *513C3-221 4H

- †1C5-30 52H
- †1C5-31 6H
- †1C5-32 4H
- †1C5-33 5H
- †1C5-34 6L
- †1C5-36 52L

- ★ Part of
- † 675C1-11 4H/5H
- † 675C1-14 52H/6H
- † 675C1-15 52L/6L

ALL PARTS SHOWN ON EXPLODED PARTS ILLUSTRATIONS ARE COMMON TO 548 AND 534 MODELS EXCEPT AS NOTED BY SYMBOLS.
 *PARTS REQUIRED FOR MODEL 534 ONLY
 †PARTS REQUIRED FOR MODEL 548 ONLY

Eastmanmachine
COMPANY
 778 WASHINGTON STREET
 BUFFALO, NEW YORK 14203



**ROUND KNIFE
MACHINES**

SHARPENER ASSEMBLY

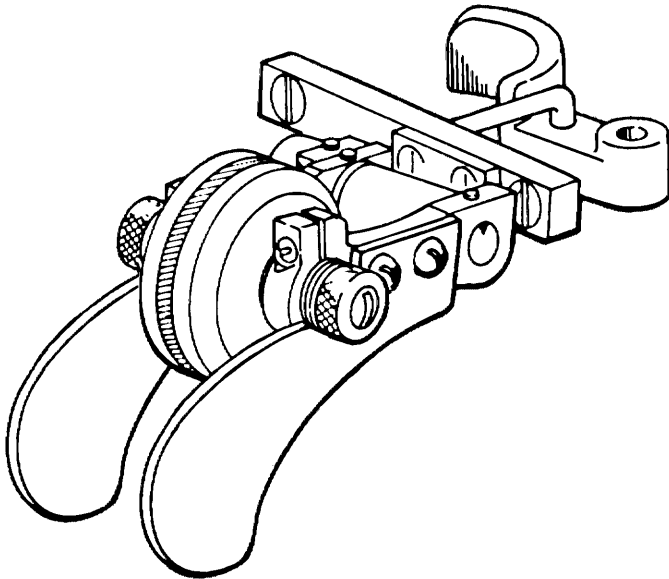

**PLEASE SPECIFY
MACHINE CLASS NUMBERS
AND SERIAL NUMBER WHEN
ORDERING PARTS**

ALL PARTS SHOWN ON EXPLODED PARTS
ILLUSTRATIONS ARE COMMON TO 534, 548, AND
562 MODELS EXCEPT AS NOTED BY SYMBOLS

*PARTS REQUIRED FOR MODEL 534 ONLY
†PARTS REQUIRED FOR MODEL 548 ONLY
●PARTS REQUIRED FOR MODEL 562 ONLY

Part No.	Description
11C10-18	SHARPENER SHAFT
12C1-28	BRASS WASHER (2 Req'd.)
12C15-29	WASHER (2 Req'd.)
12C15-70	PAPER WASHER (2 Req'd.)
17C15-71	COTTER PIN (2 Req'd.)
20C6-11	ADJUSTING SCREW (2 Req'd.)
20C8-2	SHARPENER ARM PIVOT SCREW
20C13-20	EMERY WHEEL SCREW (2 Req'd.)
25C4-160	GUARD FOR 4" KNIFE (2 Req'd.)
†25C4-161	GUARD FOR 5 & 5-1/4" KNIFE (2 Req'd.)
●†25C4-163	GUARD FOR 6 & 7-1/2" KNIFE (2 Req'd.)
34C1-20	SHARPENER SPRING
35C5-57	SHARPENER ARM
46C3-13	SHARPENER ARM BLOCK
57C2-17	SHARPENER LEVER
●57C2-22	SHARPENER LEVER
●77C1-34	SHARPENER LINK
77C1-67	SHARPENER LINK
92C1-12	SPINDLE (2 Req'd.)
133C1-11	EMERY WHEEL UNMOUNTED 120 GRIT 4" KNIFE (2 Req'd.)
133C1-12	EMERY WHEEL UNMOUNTED 120 GRIT 5"/5-1/4"/6"/7-1/2" KNIFE (2 Req'd.)
133C1-13	EMERY WHEEL UNMOUNTED 150 GRIT 4" KNIFE (2 Req'd.)
†133C1-14	EMERY WHEEL UNMOUNTED 150 GRIT 5"/5-1/4"/6"/7-1/2" KNIFE (2 Req'd.)
†133C1-24	EMERY WHEEL UNMOUNTED 220 GRIT 5"/5 1/2"/6" KNIFE (2 Req'd.)
†133C1-25	EMERY WHEEL UNMOUNTED 220 GRIT 5"/5-1/4"/6"/7-1/2" (2 Req'd.)
300C8-8	SCREW 4-40 x 5/16 R.H. (4 Req'd.)
300C10-5	SCREW, 6-32 x 7/16 ROUND HEAD (2 Req'd.)
302C12-3	SCREW, 8-32 x 3/8 FLAT HEAD (2 Req'd.)
304C10-3	SPINDLE LOCK SCREW (2 Req'd.)
309C12-1	SOC. SET SCR 8-32 x 187 CUP PT.
309C12-4	SET SCREW (3 Req'd.)
540C1-45	L.H. ARM WITH WHEEL 120 GRIT 4" KNIFE
540C1-53	R.H. ARM WITH WHEEL 120 GRIT 4" KNIFE
†540C1-47	L.H. ARM WITH WHEEL 120 GRIT 5"/5 1/2"/6" KNIFE
†540C1-54	R.H. ARM WITH WHEEL 120 GRIT 5"/5 1/2"/6" KNIFE
●540C1-49	L.H. ARM WITH WHEEL 120 GRIT 6" KNIFE
●540C1-55	R.H. ARM WITH WHEEL 120 GRIT 6" KNIFE
●540C1-51	L.H. ARM WITH WHEEL 120 GRIT 7-1/2" KNIFE
●540C1-56	R.H. ARM WITH WHEEL 120 GRIT 7-1/2" KNIFE
●†541C1-9	EMERY WHEEL MOUNTED 120 GRIT 5"/5 1/2"/6" KNIFE (2 Req'd.)
541C1-10	EMERY WHEEL MOUNTED 120 GRIT 4" KNIFE (2 Req'd.)
●†541C1-13	EMERY WHEEL MOUNTED 150 GRIT 5"/5 1/2"/6" KNIFE (2 Req'd.)
541C1-14	EMERY WHEEL MOUNTED 150 GRIT 4" KNIFE (2 Req'd.)
541C1-20	EMERY WHEEL MOUNTED 220 GRIT 4" KNIFE (2 Req'd.)
●†541C1-21	EMERY WHEEL MOUNTED 220 GRIT 5"/5 1/2"/6" KNIFE (2 Req'd.)
636C1-8	SHARPENER ARM BRACKET 4" KNIFE
†636C1-9	SHARPENER ARM BRACKET 5" KNIFE (BK)
†636C1-10	SHARPENER ARM BRACKET 5-1/4" KNIFE
†636C1-11	SHARPENER ARM BRACKET 6" KNIFE
●636C1-13	SHARPENER ARM BRACKET 6x & 75x KNIFE
637C1-25	SHARPENER COMPLETE 4" KNIFE
637C1-26	SHARPENER COMPLETE 5" KNIFE
637C1-27	SHARPENER COMPLETE 5-1/4" KNIFE
637C1-28	SHARPENER COMPLETE 6" KNIFE
●637C1-30	SHARPENER COMPLETE 6x & 75x KNIFE
12C1-21	LOCK WASHER
35C5-65	SHARPENER ARM
300C12-3	SCREW, 8-32 X 3/8 RD. HD.

From the library of: Diamond Needle Corp

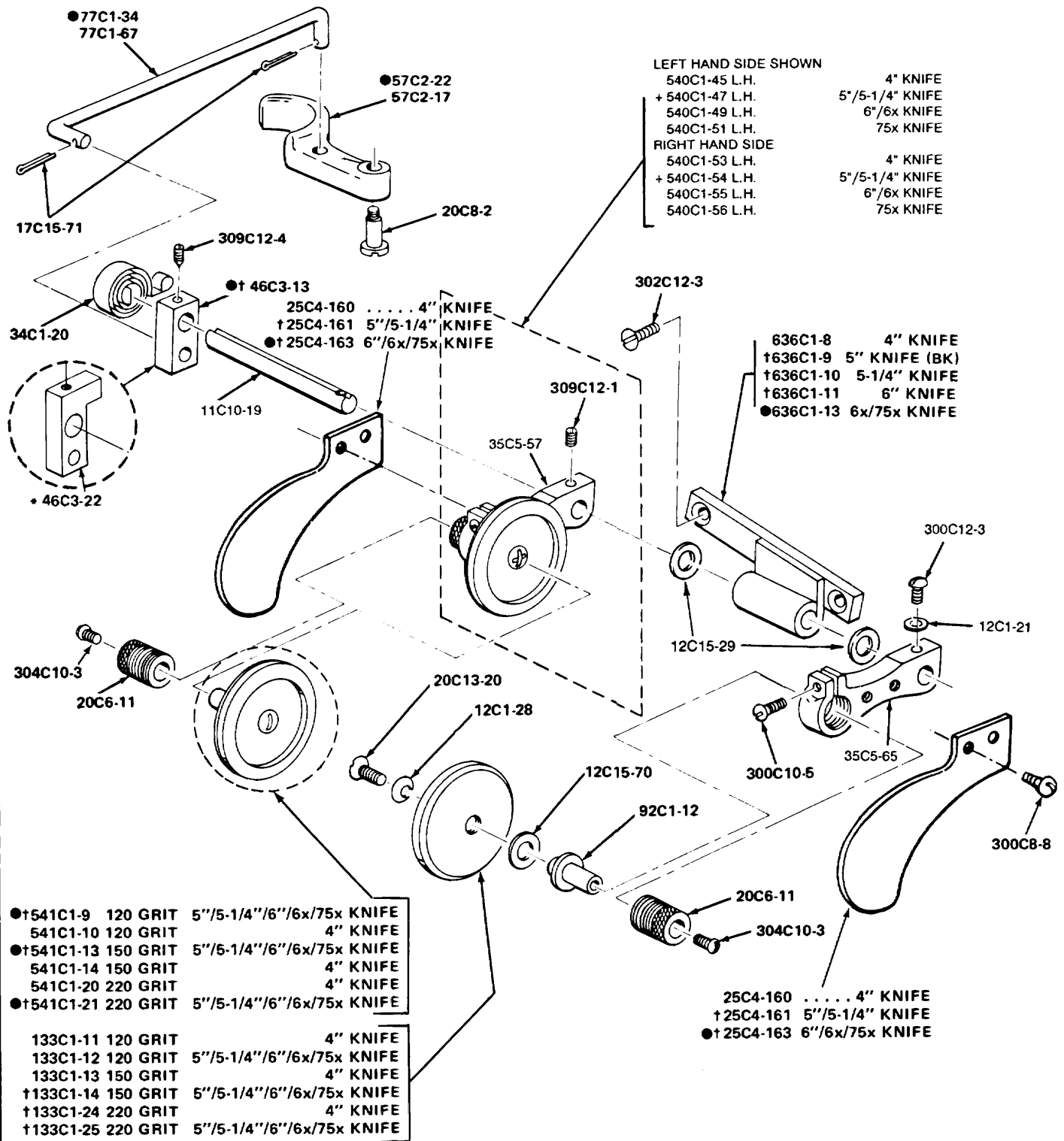

ALL PARTS SHOWN ON EXPLODED PARTS ILLUSTRATIONS ARE COMMON TO 534, 548, AND 562 MODELS EXCEPT AS NOTED BY SYMBOLS

*PARTS REQUIRED FOR MODEL 534 ONLY
 †PARTS REQUIRED FOR MODEL 548 ONLY
 ●PARTS REQUIRED FOR MODEL 562 ONLY

Eastman machine
COMPANY
 779 WASHINGTON STREET
 BUFFALO, NEW YORK 14203



**ROUND KNIFE
MACHINES**

**STANDARD
ASSEMBLY**

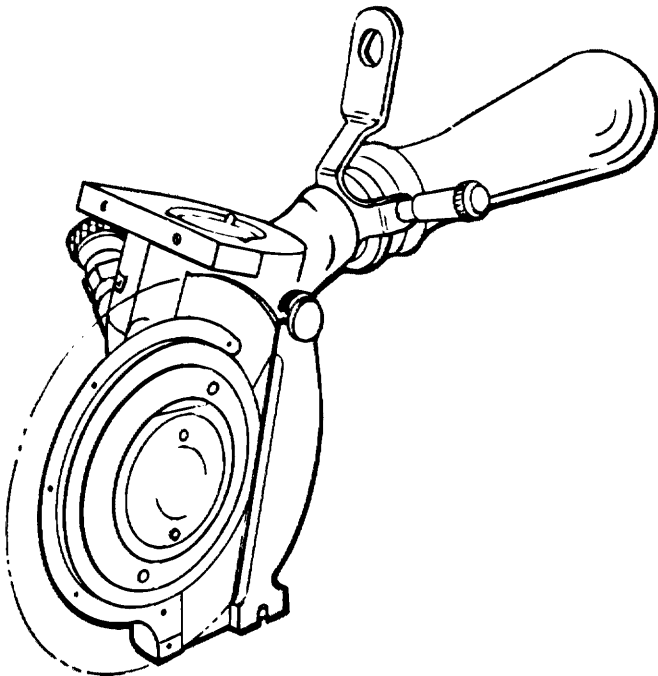

**PLEASE SPECIFY
MACHINE CLASS NUMBERS
AND SERIAL NUMBER WHEN
ORDERING PARTS**

ALL PARTS SHOWN ON EXPLODED PARTS
ILLUSTRATIONS ARE COMMON TO 548 AND
534 MODELS EXCEPT AS NOTED BY SYMBOLS.

*PARTS REQUIRED FOR MODEL 534 ONLY
†PARTS REQUIRED FOR MODEL 548 ONLY
★INCLUDES MOTOR DRIVE GEAR (See Pg. 8) OR
(See Pg. 9)

Part No.	Description
4C1-81	KNIFE LOCK NUT 4"/5" KNIFE
†4C1-82	KNIFE LOCK NUT 5-1/4"/6" KNIFE
†4C1-113	KNIFE GEAR BEARING LOCK NUT 5-1/4"/6" KNIFE
4C1-114	KNIFE GEAR BEARING LOCK NUT 4"/5" KNIFE
†4C1-130	OPERATING HANDLE LOCK NUT
*4C1-115	OPERATING HANDLE LOCK NUT
4C4	SIDE GUIDE NUT
12C9-7	KNIFE GEAR SHIMS 52H/52L/6H/6L
12C9-8	KNIFE GEAR SHIMS 4H/5H
†13C2-5	SWITCH LEVER KNOB
17C1-4	STANDARD PIN (2 Req'd.)
†20C4-28	KNIFE BEARING LOCK SCREW 5-1/4"/6" KNIFE
20C4-29	KNIFE BEARING LOCK SCREW 4"/5" KNIFE
24C6	SIDE GUARD SCREW
25C4-137	SIDE GUARD 4" KNIFE
†25C4-138	SIDE GUARD 5 1/2" KNIFE
†25C4-140	SIDE GUARD 6" KNIFE
29C6-141	HANDLE ADAPTER
53C4-36	GEAR COVER 52H/52L
53C4-47	GEAR COVER 6H/6L
53C4-64	GEAR COVER 4H
53C4-65	GEAR COVER 5H
†57C1-56	SWITCH LEVER
72C4-20	GREASE CUP
†87C2-21	KNIFE GEAR 52H/6H
†87C2-24	KNIFE GEAR 52L/6L
87C2-36	KNIFE GEAR 4H/5H
90C6-9	KNIFE GEAR BALL BEARING 4"/5" KNIFE
†90C6-33	KNIFE GEAR BALL BEARING 5-1/4"/6" KNIFE
†216C1-1	BEARING SEAL 5-1/4"/6" KNIFE
216C1-2	BEARING SEAL 4"/5" KNIFE
300C12-7	SCREW, 8-32 x 5/8" ROUND HD. (2 Req'd.)
†302C12-2	SCREW, 8-32 x 5/16" FLAT HD.
†511C1-94	STANDARD COMPLETE 52L
†511C1-96	STANDARD COMPLETE 52H
511C1-97	STANDARD COMPLETE 4H
†511C1-101	STANDARD COMPLETE 6H
†511C1-102	STANDARD COMPLETE 6L
*531C1-13	OPERATING HANDLE
†531C1-53	OPERATING HANDLE
★675C1-11	DRIVE GEAR SET 4H/5H
†★675C1-14	DRIVE GEAR SET 52H/6H
†★675C1-15	DRIVE GEAR SET 52L/6L

From the library of: Diamond Needle Corp

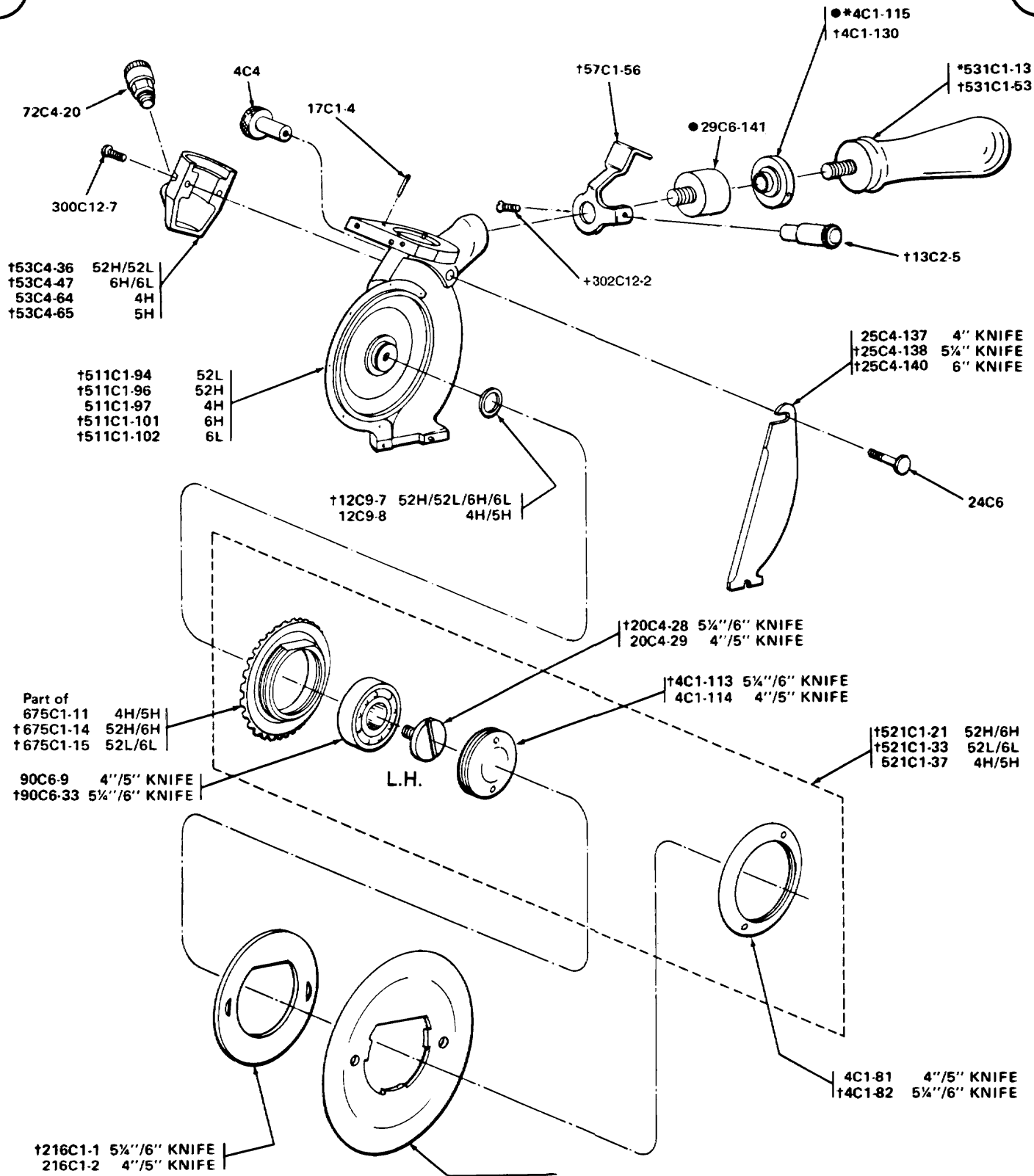

†53C4-36 52H/52L
 †53C4-47 6H/6L
 53C4-64 4H
 †53C4-65 5H

†511C1-94 52L
 †511C1-96 52H
 511C1-97 4H
 †511C1-101 6H
 †511C1-102 6L

†12C9-7 52H/52L/6H/6L
 12C9-8 4H/5H

Part of
 †675C1-11 4H/5H
 †675C1-14 52H/6H
 †675C1-15 52L/6L

90C6-9 4"/5" KNIFE
 †90C6-33 5"/6" KNIFE

L.H.

†20C4-28 5"/6" KNIFE
 20C4-29 4"/5" KNIFE

†4C1-113 5"/6" KNIFE
 4C1-114 4"/5" KNIFE

†521C1-21 52H/6H
 †521C1-33 52L/6L
 521C1-37 4H/5H

4C1-81 4"/5" KNIFE
 †4C1-82 5"/6" KNIFE

†216C1-1 5"/6" KNIFE
 216C1-2 4"/5" KNIFE

FOR KNIFE
 SEE PAGE 18

ALL PARTS SHOWN ON EXPLODED PARTS ILLUSTRATIONS ARE COMMON TO 548 AND 534 MODELS EXCEPT AS NOTED BY SYMBOLS.

●PARTS REQUIRED FOR MODEL 534 ONLY
 †PARTS REQUIRED FOR MODEL 548 ONLY
 ●PARTS REQUIRED FOR MODEL 562 ONLY

Eastmanmachine
COMPANY

779 WASHINGTON STREET
 BUFFALO, NEW YORK 14203

From the library of: Diamond Needle Corp



**EASTMAN
CARDINAL®**

**ROUND KNIFE
MACHINES**

**GUARD AND
BASE PLATE
ASSEMBLY**

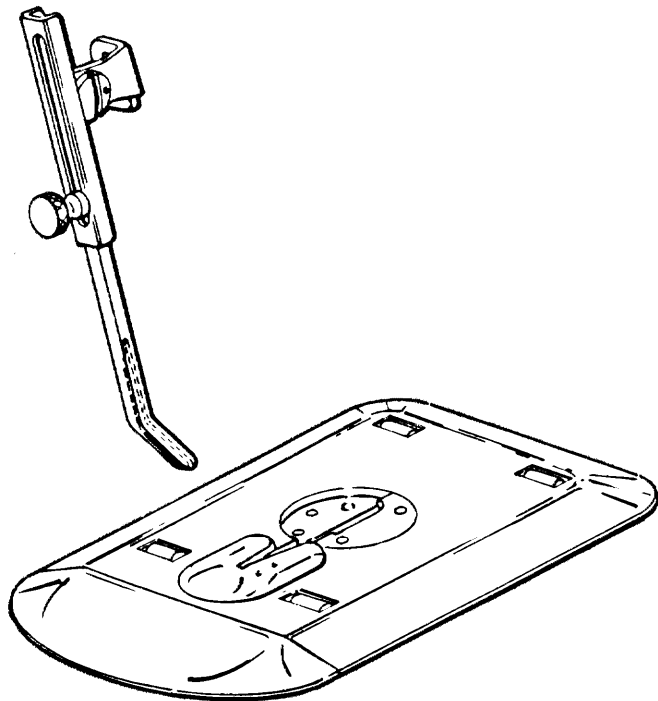

**PLEASE SPECIFY
MACHINE CLASS NUMBERS
AND SERIAL NUMBER WHEN
ORDERING PARTS**

ALL PARTS SHOWN ON EXPLODED PARTS
ILLUSTRATIONS ARE COMMON TO 548 AND
534 MODELS EXCEPT AS NOTED BY SYMBOLS.

*PARTS REQUIRED FOR MODEL 534 ONLY
†PARTS REQUIRED FOR MODEL 548 ONLY

GUARD ASSEMBLY

Part No.	Description
4C2-93	SPLINE NUT
12C15-103	WASHER
17C15-123	PIN
20C4-38	LOCK SCREW
20C5-2	GUARD ROD SCREW
33C4-23	GUARD ROD HOLDER 4"/5"/5-1/4" KNIVES
†33C4-24	GUARD ROD HOLDER 6" KNIFE
†62C9-80	GUARD ROD HOLDER BRACKET
*62C9-81	GUARD ROD HOLDER BRACKET
†65C2-67	GUARD ROD 5"/5-1/4"/6" KNIVES
65C2-66	GUARD ROD 4" KNIFE
300C12-13	SCREW, 8-32 x 5/16 ROUND HD. (2 Req'd.)

BASE PLATE ASSEMBLY

Part No.	Description
11C2-3	REAR ROLLER SHAFT
11C2-4	FRONT ROLLER SHAFT (2 Req'd.)
12C8-1	ROLLER SHAFT WASHER (8 Req'd.)
12C15-3	THROAT PLATE WASHER (2 Req'd.)
17C6	HINGE PIN 4" KNIFE (2 Req'd.)
+ 17C6-10	HINGE PIN 5-1/4"/6" KNIFE (2 Req'd.)
20C13-72	SCREW - BASE PLATE TO STANDARD (3 Req'd.)
41C2	PLATE ROLLER BEARING (40 Req'd.)
+ 60C1-44	PLATE WING 5-1/4"/6" KNIFE
60C1-54	PLATE WING 4" KNIFE
61C1-1	ROLLER SHELL (4 Req'd.)
76C2-44	PLATE FILLER
+ 79C5-155	4"/5-1/4" THROAT PLATE
+ 79C5-184	6" THROAT PLATE
+ 79C5-185	5" THROAT PLATE
98C4-11	SHORT CLIP (2 Req'd.)
98C4-12	LONG CLIP (2 Req'd.)
300C10-3	SCREW, 6-32 X 5/16 ROUND HD. (2 Req'd.)
302C10-1	SCREW, 6-32 X 3/16 FLAT HD. (10 Req'd.)
302C14-11	SCREW, 10-24 X 1/2 FLAT HD. (2 Req'd.)
+ 505C3-191	BASE PLATE COMPLETE 5-1/4"/6" KNIFE
505C3-203	BASE PLATE COMPLETE 4" KNIFE
622C1-2	FRONT ROLLER COMPLETE (4 Req'd.)

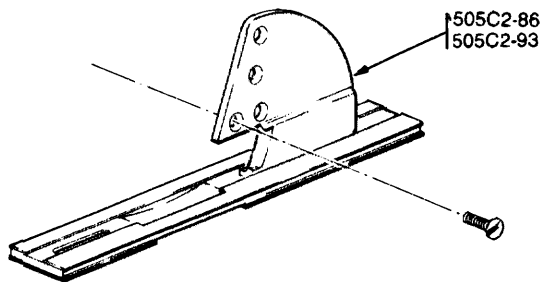

BASE PLATE ASSEMBLY

Part No.	Description
505C2-86	BASE PLATE ASSEMBLY, FALCON TRACK (534 4" BK / 548 4" BK)
505C2-93	BASE PLATE ASSEMBLY, FALCON TRACK (534 5" BK / 548 5" BK)

From the library of: Diamond Needle Corp

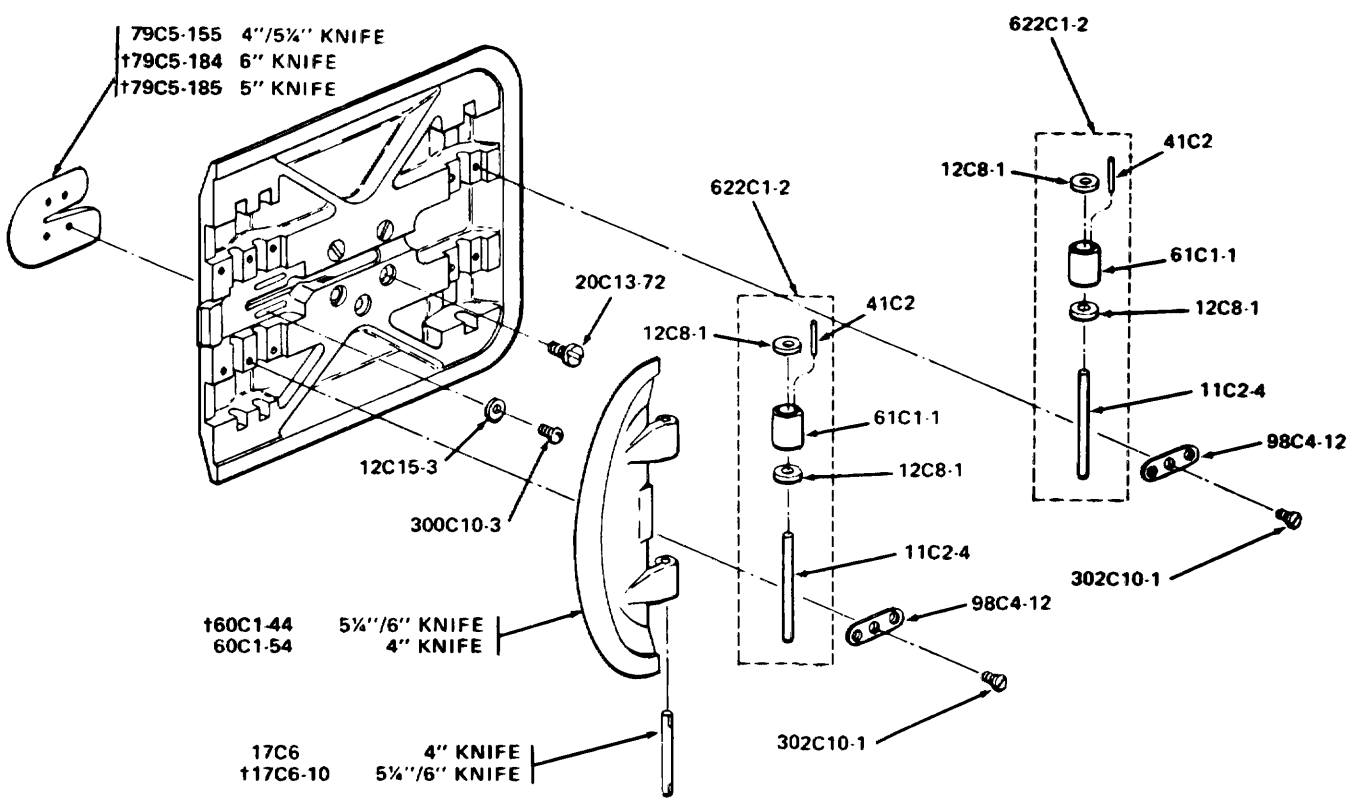
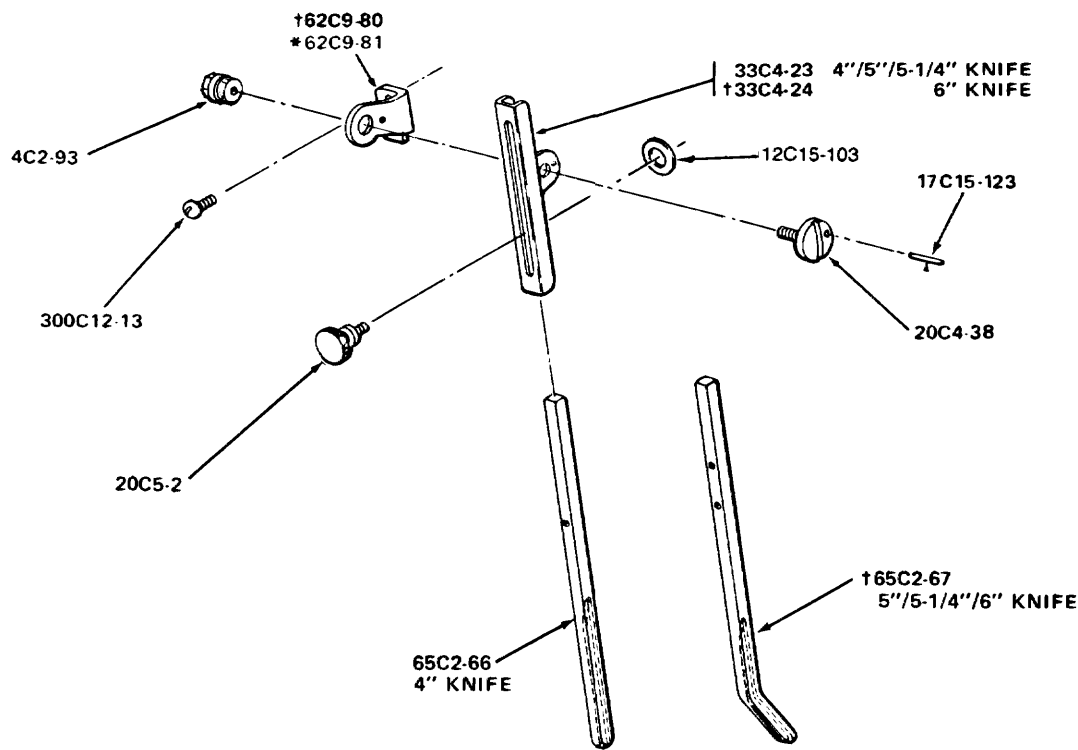

†505C3-191 BASE PLATE COMPLETE 5-1/4"/6" KNIFE
 *505C3-203 BASE PLATE COMPLETE 4" KNIFE

ALL PARTS SHOWN ON EXPLODED PARTS ILLUSTRATIONS ARE COMMON TO 548 AND 534 MODELS EXCEPT AS NOTED BY SYMBOLS.

*PARTS REQUIRED FOR MODEL 534 ONLY
 †PARTS REQUIRED FOR MODEL 548 ONLY

Eastman machine
COMPANY
 778 WASHINGTON STREET
 BUFFALO, NEW YORK 14203

From the library of: Diamond Needle Corp

ILLUSTRATED PARTS LIST

EASTMAN 548 BK AND **CARPET CUTTER** ROUND KNIVES

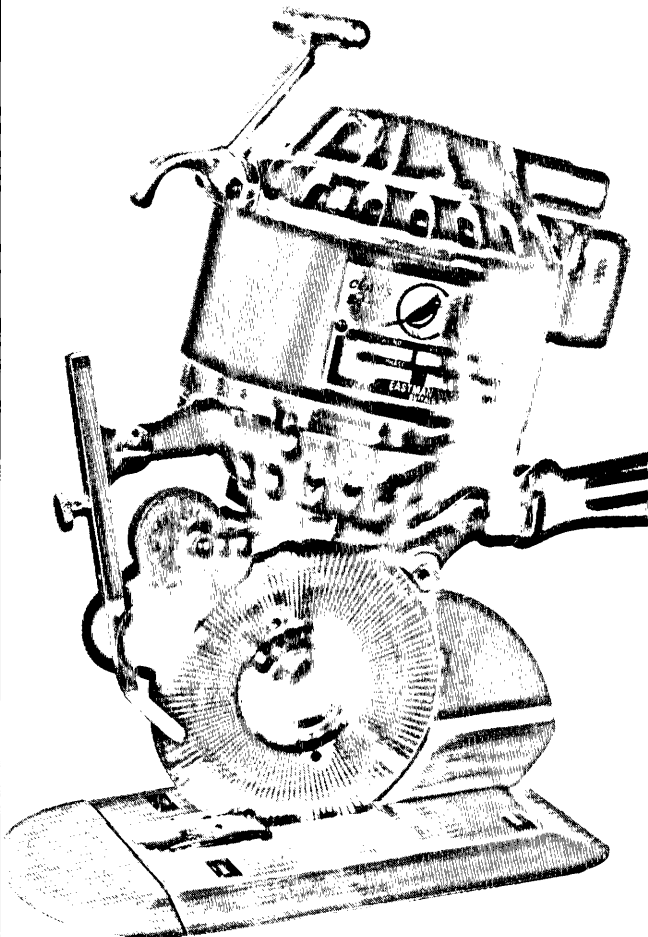

PLEASE SPECIFY
MACHINE CLASS NUMBERS
AND SERIAL NUMBER WHEN
ORDERING PARTS

ALL PARTS SHOWN ON EXPLODED PARTS
ILLUSTRATIONS ARE COMMON TO 548 AND
534 MODELS EXCEPT AS NOTED BY SYMBOLS.

*PARTS REQUIRED FOR MODEL 534 ONLY
†PARTS REQUIRED FOR MODEL 548 ONLY

THE PARTS LISTED HERE ARE SPECIAL FOR THE BK AND CC MACHINES ONLY. ALL OTHER PARTS OF MACHINE NOT LISTED HERE ARE STANDARD AND CAN BE FOUND IN THE CARDINAL ROUND KNIFE ILLUSTRATED PARTS LIST COVERED IN THIS CATALOG.

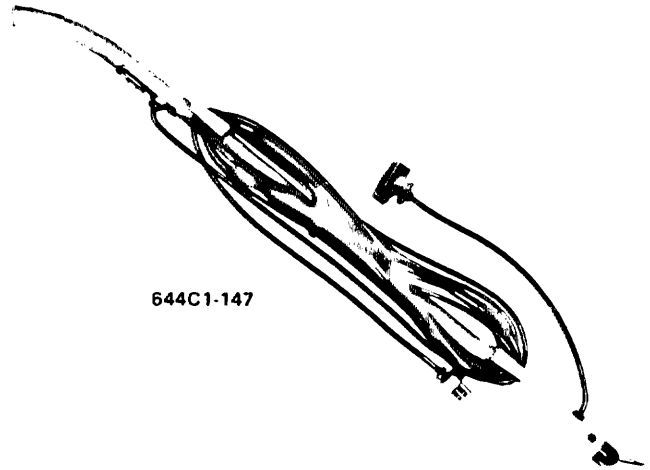

644C1-147

Part No.	Description
4C2-110	STOP NUT (4 or 5 as Req'd.)
4C1-185	KNIFE LOCKNUT (For grooved knife)
12C15-3	WASHER (Throat plate) (2 Req'd.)
17C6	PIN, HINGE (2 Req'd.)
20C13-78	SETSCREW (For locknut 4C1-185) (3 Req'd.)
60C1-15	WING, PLATE
62C16-203	STEEL BRACKET ONLY, 5" KNIFE
62C16-207	STEEL BRACKET ONLY, 4" KNIFE
79C5-185	THROAT PLATE 5" KNIFE
79C5-256	THROAT PLATE 4" KNIFE
98C4-11	CLIPS, SHORT (2 Req'd.)
98C4-12	CLIPS, LONG (2 Req'd.)
300C10-3	SCREW, THROAT PLATE, RD HD. (2 Req'd.)
302C10-1	SCREW, 6-32 X 3/16 FLAT HD. (10 Req'd.)
302C12-3	SCREW, 8-32 X 3/8 FLAT HD. (3 Req'd.)
302C12-5	SCREW, 8-32 X 1/2 FLAT HD. (4 or 5 as Req'd.)
306C12-5	SCREW, 8-32 X 1/4 PAN HD. (2 Req'd.)
505C3-210	BASE PLATE (Complete)
511C1-114	STANDARD (With gear cover) 5" KNIFE
511C1-118	STANDARD (With gear cover) 4" KNIFE
511C1-122	STANDARD (With steel bracket) 4" KNIFE
511C1-123	STANDARD (With steel bracket) 5" KNIFE
622C1-2	PLATE ROLLER (Complete) (4 Req'd.)

ACCESSORIES

644C1-147 EXTENSION HANDLE (With switch and cord)

The Following Parts not Shown

302C10-5 SCREW, 6-32 x 3/8 FLAT HD. (4 Req'd.)
505C3-211 BASE PLATE (Complete with skate)
630C1-30 SKATE ONLY

From the library of: Diamond Needle Corp

FOR FASTENERS REQUIRED TO ASSEMBLE MAJOR COMPONENTS NOT LISTED ON THIS PAGE,
SEE PAGES 4 AND 5.

MOTOR ASSEMBLIES
SEE PAGES 6, 7, 8 AND 9

GUARD ASSEMBLY
SEE PAGES 14 AND 15

511C1-122 4" KNIFE
511C1-123 5" KNIFE

511C1-114 5" KNIFE
511C1-118 4" KNIFE

SEE
PAGE 13

62C16-203 5" KNIFE
62C16-207 4" KNIFE

4C2-110

SHARPENER ASSEMBLY
SEE PAGES 10 AND 11

302C12-5

4C1-185

20C13-78

FOR KNIFE
SEE PAGE 3

505C3-210

306C12-5

302C12-3
300C12-3

ALL PARTS SHOWN ON EXPLODED PARTS
ILLUSTRATIONS ARE COMMON TO 548 AND
534 MODELS EXCEPT AS NOTED BY SYMBOLS.

*PARTS REQUIRED FOR MODEL 534 ONLY
†PARTS REQUIRED FOR MODEL 548 ONLY

79C5-185 5" KNIFE
79C5-256 4" KNIFE

12C15-3

300C10-3

60C1-15

17C6

622C1-2

98C4-11

302C10-1

98C4-12

Eastmanmachine
COMPANY
778 WASHINGTON STREET
BUFFALO, NEW YORK 14203

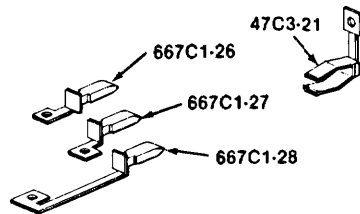
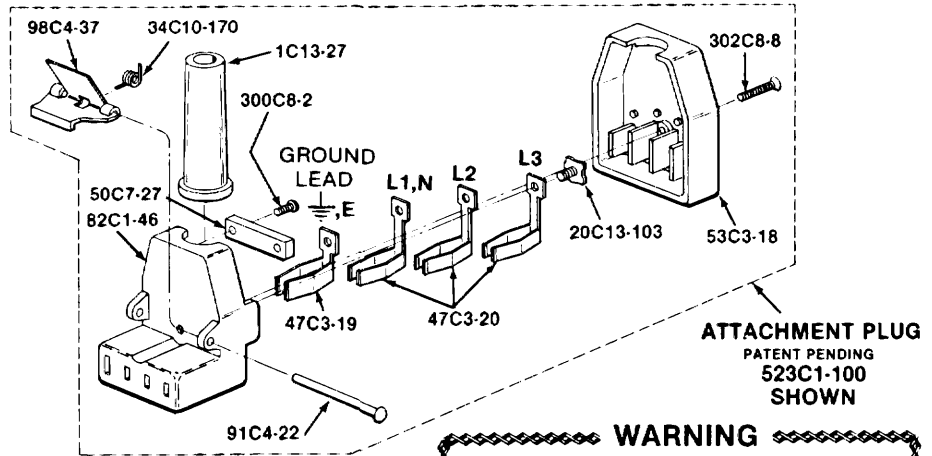
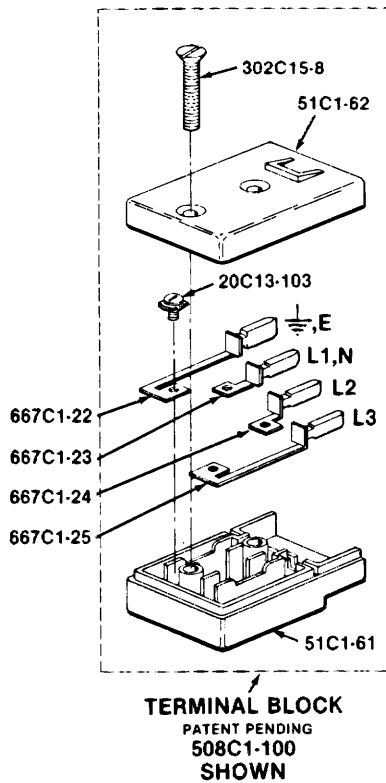

WARNING

WIRING INSTRUCTIONS
EASTMAN ATTACHMENT PLUGS

ELECTRICAL CONNECTIONS TO THIS DEVICE SHOULD BE MADE BY A QUALIFIED ELECTRICIAN WHO IS FAMILIAR WITH APPLICABLE CODES AND REGULATIONS.

TO ENSURE OPERATOR SAFETY, A GROUND LEAD MUST BE CONNECTED TO TERMINAL "E" ON THE ATTACHMENT PLUG.

DISCONNECT THIS EQUIPMENT FROM ELECTRICAL POWER BEFORE PROCEEDING WITH ANY DISASSEMBLY FOR ADJUSTMENT INSPECTION OR REPAIR.

Description	Part No.
ATTACHMENT PLUG	
CORD SLEEVE	1C13-27
U-LOCK SCREW	20C13-103
SPRING	34C10-170
TERMINAL SLEEVE	47C3-19
TERMINAL SLEEVE (current)	47C3-20
TERMINAL SLEEVE (current)	47C3-21
CORDCLAMP	50C7-27
ATTACHMENT PLUG COVER	
ATTACHMENT PLUG BODY	82C1-45
ATTACHMENT PLUG BODY	82C1-46
ATTACHMENT PLUG BODY	82C1-47
ATTACHMENT PLUG BODY	82C1-48
ATTACHMENT PLUG BODY	82C1-49
RIVET	91C4-22
THUMB CLIP	98C4-37
SCREW #4-40 x 3/8 Round Hd.	300C8-1
SCREW #4-40 x 1/2 Round Hd.	300C8-2
SCREW #4-40 x 7/8 Flat Hd.	302C8-8
TERMINAL BLOCK	
U-LOCK SCREW	20C13-103
TERMINAL BLOCK BOTTOM	51C1-61
TERMINAL BLOCK TOP	51C1-63
SCREW #10-32 x 1-1/8 Flat Hd.	302C15-8
TERMINAL CONTACT W/PIN E	667C1-22
TERMINAL CONTACT W/PIN L1, N	667C1-23
TERMINAL CONTACT W/PIN L2	667C1-24
TERMINAL CONTACT W/PIN L3	667C1-25
TERMINAL CONTACT W/PIN L1, N	667C1-26
TERMINAL CONTACT W/PIN L2	667C1-27
TERMINAL CONTACT W/PIN L3	667C1-28

	EASTMAN 10A 380V 3~	EASTMAN 10A 220V 3~	EASTMAN 10A 220V ~	EASTMAN 15A 120V ~	EASTMAN 25A 42V ~
	523C1-99	523C1-100	523C1-101	523C1-102	523C1-103
	1	1	1	1	1
	4	4	3	3	3
	1	1	1	1	1
	1	1	1	1	1
	2	3	1	1	1
	1	—	1	1	1
	1	1	1	1	1
	53C3-19	53C3-20	53C3-21	53C3-22	53C3-23
	1	—	—	—	—
	—	1	—	—	—
	—	—	1	—	—
	—	—	—	1	—
	—	—	—	—	1
	—	—	—	—	1
	1	1	1	1	1
	1	1	1	1	1
	—	—	2	2	—
	2	2	—	—	2
	1	1	1	1	1
	508C1-99	508C1-100	508C1-101	508C1-102	508C1-103
	4	4	3	3	3
	1	1	1	1	1
	51C1-63	51C1-64	51C1-65	51C1-66	51C1-67
	2	2	2	2	2
	1	1	1	1	1
	1	1	—	—	—
	1	1	—	1	—
	—	—	—	—	1
	—	—	—	1	1
	—	—	1	—	—
	1	—	—	—	—

PARTS LISTS CLASS 562 HEAVY DUTY 6X-75X CLASS 567 ★

82 (class 567 only) 514C4-xxx

Stator w/Band (specify machine voltage and serial no) ★

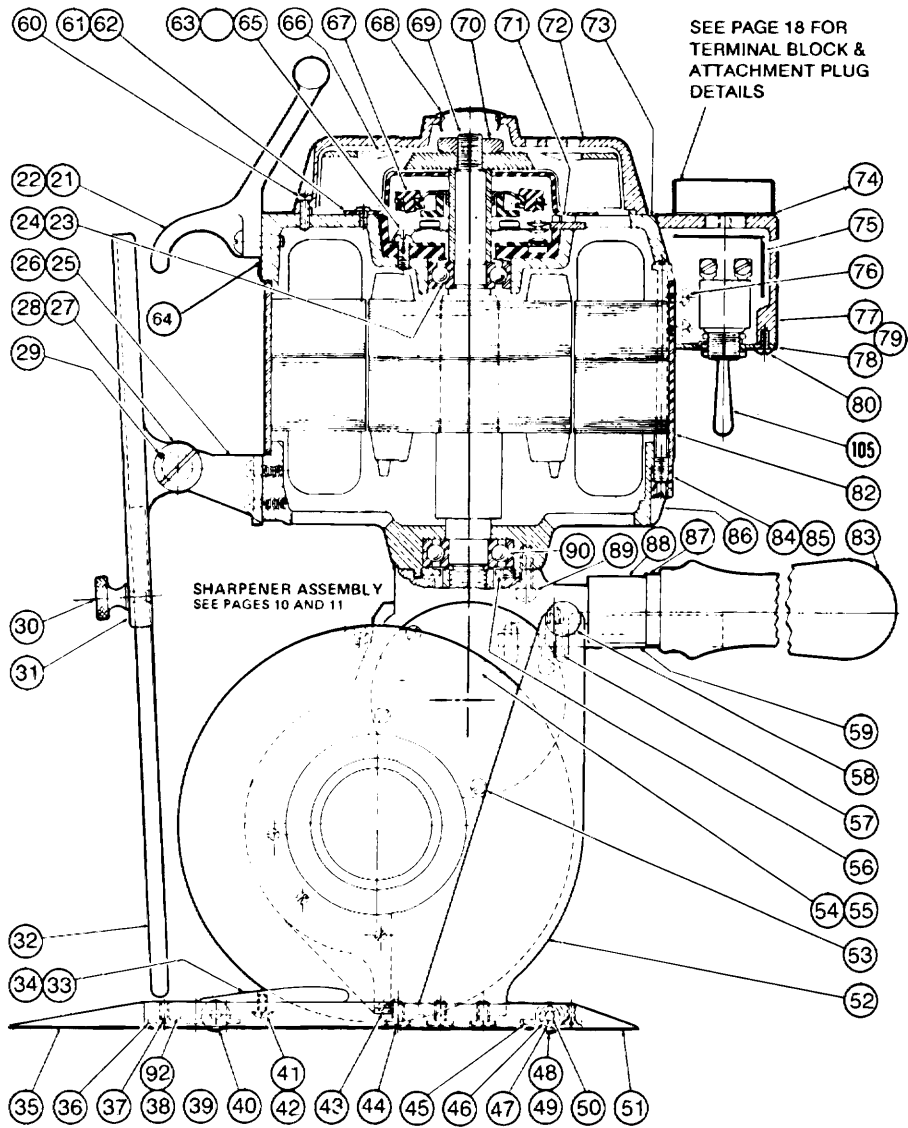
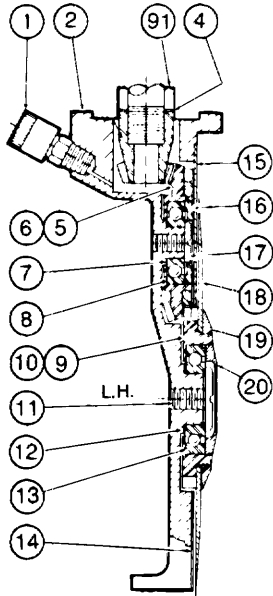

ITEM#	6X PART#	75X PART#	REQ'D	DESCRIPTION
1	72C4-20	72C4-20	1	Grease Cup
2	511C1-64	511C1-63	1	Standard with Plow
3	87C1-31	87C1-31	1	Drive Gear (available only with assembly 608C1-20, 608C1-21)
4	12C11-18	12C11-18	1	Drive Gear Spacing Washer
5	608C1-20	608C1-20	1	Intermediate Gear w/o Bearing (includes 87C1-31)
6	608C1-21	608C1-21	1	Intermediate Gear with Bearing (includes 87C1-31)
7	12C9-8	12C9-8	1	Internal Gear Spacing Washer
8	90C6-9	90C6-9	1	Internal Gear Ball Bearing
9	521C1-26	521C1-26	1	Knife Gear with Bearing
10	87C2-25	87C2-25	1	Knife Gear (ONLY)
11	20C4-30	20C4-30	1	Knife Bearing Lock Screw
12	12C9-7	12C9-7	1	Spacing Washer
13	90C6-38	90C6-33	1	Ball Bearing
14	120C1-31	120C1-10	1	Plow for Standard
15	53C4-52	53C4-52	1	Gear Cover
16	4C1-103	4C1-103	1	Internal Gear Locknut
17	20C4-26	20C4-26	1	Internal Gear Bearing Screw
18	80C1-39	80C1-77	1	Knife
19	4C1-82	4C1-82	1	Knife Locknut
20	4C1-113	4C1-113	1	Knife Bearing Locknut
21	22C1-34	22C1-34	1	Carrying Handle
22	300C14-6	300C14-6	2	10-24 x 5/8" Round Hd. Screw
23	90C6-28	90C6-28	1	Rear Ball Bearing
24	12C1-12	12C1-12	1	Loading Spring Washer
25	62C9-85	62C9-85	1	Guard Rod Holder
26	300C12-5	300C12-5	2	8-32 x 7/16" Round Hd. Screw
27	20C4-38	20C4-38	1	Lock Screw
28	4C2-93	4C2-93	1	Spline Nut
29	17C15-123	17C15-123	1	Spring Pin

ITEM#	6X PART#	75X PART#	REQ'D	DESCRIPTION
30	20C5-2	20C5-2	1	Guard Rod Adjust. Screw
31	33C4-26	33C4-26	1	Guard Rod Holder
32	65C2-35	65C2-50	1	Knife Guard Rod
33	79C5-155	79C5-155	1	Throat Plate, Low
34	79C5-188	79C5-188	1	Throat Plate, High
35	60C1-44	60C1-14	1	Plate Wing
36	98C4-12	98C4-11	2	Roller Shaft Clip
37	302C10-2	302C10-2	A/R	6-32 x 1/4" Flat Hd. Screw
38	17C6-10	17C6	2	Hinge Pin
39	11C2-4	11C2-13	2	Front Roller Shaft
40	622C1-2	622C1-4	2	Front Roller, Complete
41	300C10-2	300C10-2	2	6-32 x 1/4" Round Hd. Screw
42	12C15-4	12C15-4	2	Throat Plate Washer
43	302C3-1	302C3-1	4	2-56 x 1/4" Flat Hd. Screw
44	20C13-72	20C13-72	3	10-24 x 5/16" Binding Hd. Screw
45	98C4-11	98C4-11	2	Roller Shaft Clip
46	41C2-0	41C2-7	4	Plate Roller
47	12C8-1	12C8-1	8	Roller Washer
48	619C1-3	619C1-8	1	Rear Roller, Complete
49	61C1-1	61C1-5	4	Roller Shell
50	11C2-3	11C2-14	1	Rear Roller Shaft
51	505C3-150	505C3-51	1	Plate, Complete
52	612C1-25	612C1-16	1	Knife Side Guard
53	302C7-2	302C7-2	4	4-36 x 1/4" Flat Hd. Screw
54	17C15-71	17C15-71	2	Cotter Pin
55	77C1-34	77C1-34	1	Sharpener Link
56	4C1-87	4C1-87	1	Front Bearing Locknut
57	20C8-2	20C8-2	1	Sharpener Lever Screw
58	20C7-1	20C7-1	1	Side Guard Screw
59	57C2-22	57C2-22	1	Sharpener Lever
60	301C8-1	301C8-1	3	4-40 x 1/2" Filler Hd. Screw
61	30C1-8	30C1-8	1	Cover for Cutout
62	305C8-1	305C8-1	3	4-10 x 1/4" Binding Hd. Screw

ITEM#	6X PART#	75X PART#	REQ'D	DESCRIPTION
63	580C1-192	580C1-192	1	Automatic Cutout Switch
64	54C4-78	54C4-78	1	Plug For Hole
65	300C12-5	300C12-5	2	8-32 x 7/16" Round Hd. Screw
66	10C1-43	10C1-43	1	Rotor Fan
67	597C2-14	597C2-14	12	Automatic Cutout
68	54C4-57	54C4-57	1	Snap Hole Plug
69	513C1-57	513C1-58	1	Rotor with Shaft
70	4C1-74	4C1-74	1	Shaft Locknut
71	8C12-4	8C12-4	2	Lead Wire Insulation
72	53C7-35	53C7-35	1	Fan Cover
73	90C1-157	90C1-157	1	Rear Bearing Housing
74	55C4-93	55C4-99	1	Terminal Block Spacer
75	8C4-67	8C4-67	1	Switch Insulation
76	300C12-13	300C12-13	4	8-32 x 5/16" Round Hd. Screw
77	62C1-169	62C1-169	1	Switch Bracket
78	52C5-184	52C5-184	1	Switch Base
79	626C1-44	626C1-44	1	Switch Bracket Ass'y Includes 62C1-169 & 52C5-184
80	300C7-3	300C7-3	4	4-36 x 1/4" Round Hd. Screw
81	580C1-65	580C1-65	1	Switch
82	514C4-xxx	514C4-xxx	1	Stator with Band (Specify machine voltage and serial number)
83	531C1-53	531C1-53	1	Machine Handle
84	4C1-179	4C1-179	4	Front to Rear Bearing Nut
85	20C3-29	20C3-29	4	Front to Rear Bearing Screw
86	90C2-145	90C2-145	1	Front Bearing Housing
87	4C1-115	4C1-115	1	Machining Handle Locknut
88	29C6-50	29C6-50	1	Handle Adaptor
89	3080C14-1	3080C14-1	1	10-24 x 1" Allen Hd. Screw
90	90C6-29	90C6-29	1	Front Ball Bearing
91	N/A	1C5-38	1	Drive Gear Spacing Sleeve
92	20C5-12	20C5-12	4	Clamp Screw
93	511C1-125	511C1-125	1	Standard, Bracket Assembly

From the library of: Diamond Needle Corp



242C2



162C2



EMERY WHEELS

17C11

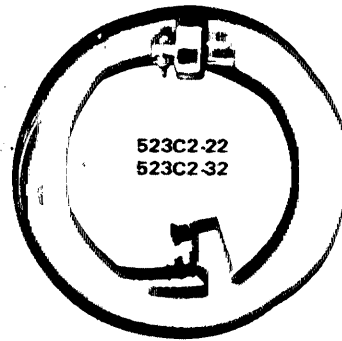

523C2-22
523C2-32



95C1-12
95C1-13

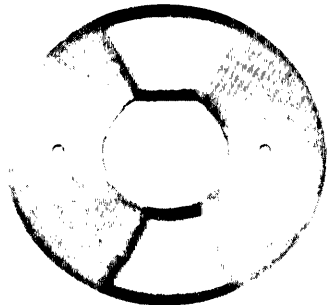

KNIVES



242C2-2



612C1-58
612C1-59
612C1-60

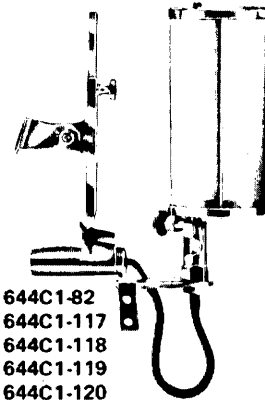

644C1-82
644C1-117
644C1-118
644C1-119
644C1-120



34C9-9

MAINTENANCE SUPPLIES

Part No.	Description
17C11	KNIFE REMOVAL PIN
95C1-12	SPANNER WRENCH 4" AND 5" KNIFE
95C1-13	SPANNER WRENCH 5-1/4 - 7" KNIFE
162C2	OIL CAN
242C2	EASTMAN GEAR LUBRICANT
242C2-2	EASTMAN BEARING GREASE
KNIVES	SEE PAGE 3
EMERY WHEELS	SEE PAGE 3

OPTIONAL EQUIPMENT

Part No.	Description
34C9-9	TROLLEY SPRING
523C2-22	CORD COMPLETE WITH PLUGS, 3 WIRE WITH GROUND (Single phase)
523C2-32	CORD COMPLETE WITH PLUGS, 4 WIRE WITH GROUND (Three phase)
612C1-58	GUARD 4" KNIFE
612C1-59	GUARD 5", 5-1/4", 6" KNIFE
612C1-60	GUARD 7-1/2" KNIFE
644C1-82	PLASTIC MASTER 7-1/2" KNIFE
644C1-117	PLASTIC MASTER 4" KNIFE
644C1-118	PLASTIC MASTER 5" KNIFE
644C1-119	PLASTIC MASTER 5-1/4" KNIFE
644C1-120	PLASTIC MASTER 6" KNIFE

Limited Warranty. Eastman warrants to the buyer that the Cardinal shall be free from defects in materials or workmanship for a period of 180 days commencing on the date of invoice. Any goods or parts claimed by the buyer to be defective must be returned to Eastman, freight charges prepaid, within the 180-day warranty period. If Eastman determines that the goods or parts are defective in materials or workmanship, Eastman's sole obligation under this warranty shall be, at Eastman's sole option, to repair or replace the defective goods or parts or to provide the buyer a credit equal to the portion of the purchase price allocable to the defective goods or parts. This warranty shall not apply if defects are caused by product misuse or neglect, if the machine has been altered or modified by the buyer, or if other than genuine Eastman belts, emery wheels, knives or parts are used in the machine. THIS WARRANTY IS THE ONLY WARRANTY APPLICABLE TO THIS PURCHASE. SELLER DISCLAIMS ALL OTHER WARRANTIES, EXPRESS OR IMPLIED, INCLUDING, BUT NOT LIMITED TO, THE IMPLIED WARRANTIES OF MERCHANTABILITY AND FITNESS FOR A PARTICULAR PURPOSE.

Limitation of Liability. Eastman's liability to the buyer, and the buyer's remedies from Eastman, whether in contract, negligence, tort, under any warranty or otherwise, shall be limited to the remedies provided in the foregoing Limited Warranty. In no event shall Eastman have any responsibility or liability to the buyer for (a) any special, indirect, incidental, or consequential damages, including, but not limited to, loss of use, revenue, or profit, even if Eastman has been advised of the possibility of such damages, or (b) any claim against the buyer by any third party. The price stated for the product sold is a consideration for limiting Eastman's liability.



779 Washington St., Buffalo, N.Y. 14203-1396 U.S.A. • (716)856-2200 • Fax (716)856-1140 or (716)856-2068
Manufacturers of Eastman Cloth Cutting and Cloth Spreading Machines

From the library of: Diamond Needle Corp